

Untruths and consequences: the false hypothesis linking CHAT type 1 polio vaccination to the origin of human immunodeficiency virus†‡

Stanley A. Plotkin

University of Pennsylvania, Wistar Institute, 4650 Wistar Road, Doylestown, PA 18901, USA (stanley.plotkin@aventis.com)

A book published in 1999 hypothesized that the scientists who worked with the CHAT type 1 attenuated polio strain tested in the former Belgian Congo in the late 1950s had covertly prepared the vaccine in chimpanzee kidney cells contaminated with a simian immunodeficiency virus, which evolved into HIV-1 group M. This paper summarizes the results of the investigation conducted by the author to determine the legitimacy of the accusation. Testimony by eyewitnesses, documents of the time, epidemiological analysis, and ancillary phylogenetic, virologic and PCR data all concur to reject the hypothesis as false and without factual foundation.

Keywords: CHAT; HIV; polio vaccine; HIV origin

1. INTRODUCTION

We pay more attention to a single story told well (even if false) than to reams of hard data (even if accurate) (Pigliucci 2000).

This is the strangest paper I have ever given, belonging perhaps more to the world of literary exegesis than to the world of science. However, it is time that the true history be told about the oral polio vaccine (OPV) that was tested more than 40 years ago in the then Belgian Congo (Courtois *et al.* 1958), to correct the misrepresentations that have been widely disseminated by *The river* (Hooper 1999) and subsequently by articles written about the book.

The evidence I present is based on papers and documents of the time from my personal files and elsewhere, on testimony from people whom Mr Hooper also interviewed and from some he did not, and on close examination of the basis for the allegations in his book.

Analysis of Mr Hooper's lengthy work reveals that the argument against CHAT, the precursor of HIV-1, boils down to two assertions: (i) that the vaccine was prepared in the kidneys of SIV-infected chimpanzees obtained from a colony established in the Belgian Congo; and (ii) that there was a coincidence in place between administration of the vaccine and early cases of AIDS. I will now respond to both of those assertions. (A

companion paper, containing parts of the present article, plus additional material, has recently been published (Plotkin 2001).)

2. DEVELOPMENT AND PRODUCTION OF THE CHAT TYPE 1 ATTENUATED STRAIN

The derivation of CHAT from an ancestor type 1 polio-virus called SM N-90, attenuated by passages in chick embryo and monkey kidney cell cultures, was described by Koprowski (1957). SM N-90 was serially passed four times in infants. The virus from the stool of the last infant was renamed CHAT, and was plaqued in monkey kidney monolayers. Individual plaques were submitted to neurovirulence tests, some performed in chimpanzees housed in the Belgian Congo camp. The most extensively tested virus was plaque 20, from which seven plaque derivatives were also tested for neurovirulence. The sequence was plaque 9 to plaque 13 to plaque 20 to plaque 36.

Figure 1 consists of a history of CHAT that I drew up in 1958 or early 1959. The faded pencil lines of the original document have been reinforced. Figure 1 is illuminating for several reasons, as follows.

1. The derivation of the name of the strain is stated, coming from Charleton, the name of an infant who was fed the SM N-90 predecessor of CHAT at an institution for retarded children in Sonoma, California in 1956. That the name of the strain CHAT was so derived was common knowledge around the laboratory in 1957. The name does *not* stand for 'chimp-attenuated', as suggested by Mr Hooper.
2. All passages are indicated as having been made in MK, standing for monkey kidney cells. These were cells of either rhesus or cynomolgus origin, received

†This paper is dedicated to the memories of Dr Florian Horaud and Dr Gaston Ninane, two old warriors in the fight against polio, who died just before the presentation of this paper.

‡Editor's note: this article has been reprinted with modifications from a paper published in *Clinical Infectious Diseases*. This represents a departure for The Royal Society, but we have done so to give as broad an account of this important topic as possible.

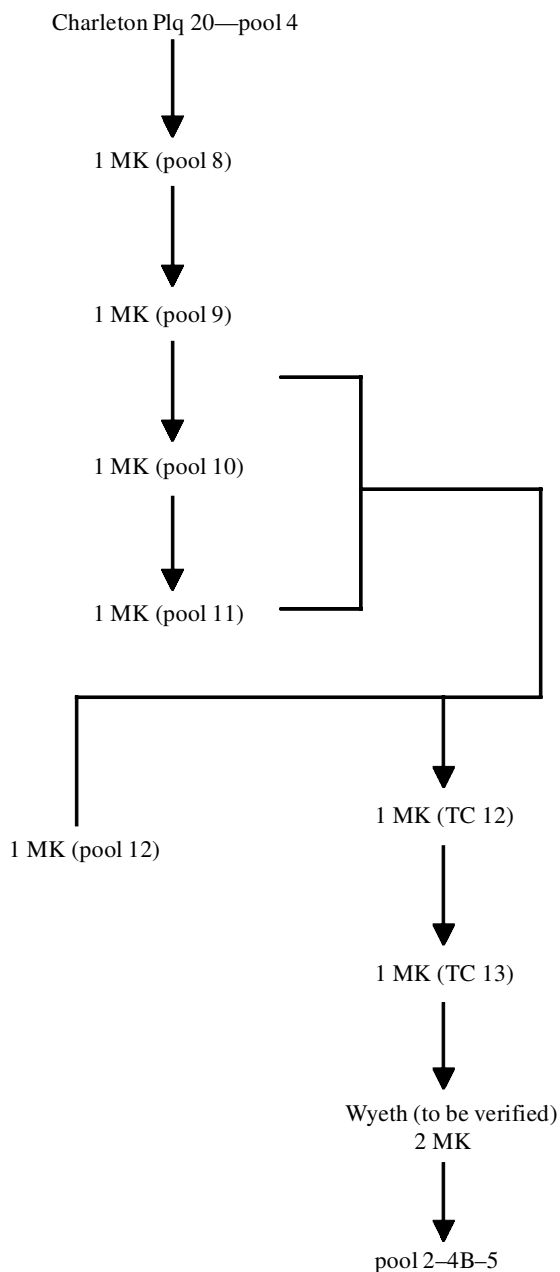

Figure 1. Chart showing passage of CHAT type 1 attenuated polio virus drawn up by S. Plotkin in 1958 or early 1959. MK, monkey kidney cells. Plq, plaque.

as suspended cells or monolayers commercially prepared by Microbiological Associates. I would have never referred to chimpanzee kidney as monkey kidney.

3. Pool 10A-11 is a mixture of pools 10 and 11, evidently to provide sufficient volume for the Congo vaccination.
4. No seed system was used. Rather, each pool served as the seed virus for a subsequent pool. Today, in order to avoid possible changes in the properties of the virus by cell culture passage, one would create a seed virus, from which all subsequent pools would be prepared. In those days, the system was to passage the virus and to check each passage for neurovirulence in primates. However, when Wyeth Laboratories, the commercial vaccine manufacturer, became involved in production of CHAT, it did produce a seed pool, which then served to produce a vaccine pool called Wyeth 2-4B-5, and later other pools.

I was in the laboratory from August 1957 to June 1961, and never saw or heard of chimpanzee cells. I also have the testimony of other people in the laboratory during the entire period that vaccine was made at the Wistar Institute. Most important, Barbara Cohen, the technician who opened Koprowski's polio laboratory at the Wistar Institute in June 1957, who was in charge of that laboratory during the entire period, and who made all of the vaccine produced at Wistar, states the following (Cohen 1999):

I came to work at Wistar in June 1957 as chief technician in the laboratory of Hilary Koprowski. I worked there until June 1961.

At no time did I ever receive or work on chimpanzee kidneys, nor to my knowledge cells derived from chimpanzees. I never made, nor know of anyone in the lab who made polio vaccine in chimpanzee cells. However, I did receive serum and stools from those animals to test for poliovirus and antibodies.

The cells used to produce the CHAT and other polio vaccines were labeled 'rhesus monkey kidney' and were obtained from a commercial supplier, I believe.

In addition, I have located four other people who were in the Koprowski polio laboratory between 1957 and 1960. Table 1 summarizes their jobs at the time and their written statements with regard to knowledge of chimpanzee kidneys or cells. It is unlikely that a batch of chimpanzee kidneys or cells could have escaped the notice of all of these people. I have also spoken to two people who prepared the CHAT vaccine at Wyeth Laboratories, Dr Howard Tint and Dr Alan Bernstein. Both deny that chimpanzee cells were ever used at Wyeth.

We and many other researchers in the late 1950s referred to animals whose kidneys were used in tissue culture as 'monkeys' or 'macaques'. Further specification of these donor animals was not necessary since no other animals were used for vaccine preparation. Just for the

Table 1. *Individuals in Wistar polio laboratory between 1957 and 1960*

name	function	comments
Hilary Koprowski	Director of Wistar Institute	never approved use of chimpanzee cells
Tom Norton	Institute laboratory chief	deceased
Barbara Cohen	Chief Technician	made all CHAT vaccines. Never saw/heard of chimpanzee cells
Stanley Plotkin	postdoctoral student	never saw/heard of chimpanzee cells
Richard Carp	postdoctoral student	never saw/heard of chimpanzee cells
Gail Theiss	predoctoral student	never saw/heard of chimpanzee cells
Anne Kamrin	technician	never saw/heard of chimpanzee cells
Susan Richardson	technician	never saw/heard of chimpanzee cells

Table 2. Articles in which substrate of CHAT vaccine is given as 'rhesus or cynomolgus monkey kidney' or 'MK'

year	locus	authors
1957	<i>Spec. Publ. NY Acad. Sci.</i>	Koprowski (1957)
1959	<i>JAMA</i>	Plotkin <i>et al.</i> (1959a)
1960	<i>Congr. Microbiol. Stand.</i>	Plotkin (1961)
1960	CHAT protocol, lot 23	Anonymous (1960)
1961	<i>JAMA</i>	Koprowski (1961)
1961	<i>Virology</i>	Plotkin <i>et al.</i> (1961a)
1962	World Health Organization	Norton <i>et al.</i> (1962)
1962	<i>Am. J. Hyg.</i>	Hayflick <i>et al.</i> (1962)
1965	<i>Am. J. Dis. Child</i>	Plotkin <i>et al.</i> (1966)

fun of it, I examined two references of that era extensively cited by Mr Hooper: the New York Academy of Sciences Symposium in 1957, and the Pan American Health Organization Conference of 1959. Although numerous researchers gave papers on live polio vaccine development, in none of the papers is the species of the monkey substrate cited. The only time the species is mentioned is during one of the discussions when Sabin mentions that he has not seen B virus in his rhesus cultures.

However, in a paper published in 1961, Koprowski wrote that: 'The material used for growing poliovirus in tissue culture consists of living cells obtained from the freshly harvested kidneys from monkeys brought to the US either from India or from the Philippines' (Koprowski 1961).

Also, in 1961, in a paper about the intratypic serodifferentiation of polioviruses, I tested five lots of the CHAT virus (Plotkin *et al.* 1961a). The material and methods section says: 'Primary cultures of monkey kidney cells were used in all the work described here, except in the case of a single pool of CHAT virus which was prepared in a culture of human diploid cells as described elsewhere'. In a table the pools that were produced outside of the Wistar Institute (namely in Belgium and Wyeth Laboratories) are specified, and also the lot that was produced in human diploid cells, which was specified as an exceptional cell substrate.

In 1960 I gave a paper shortly after the discovery of SV40 in rhesus monkey kidney cells (Plotkin 1961). The text refers to that discovery and discusses the medical follow-up of infants vaccinated with Koprowski OPV strains to determine if any had developed cancer, and it also discusses certain laboratory studies:

Despite the probable harmlessness of these adventitious agents, two lines of research are being pursued at the Wistar Institute in an effort to obtain live-virus vaccines containing only poliovirus. First is an attempt to purify live-virus vaccine by passage through a cellulose ion exchange resin. In this technique, virus prepared in Rhesus monkey kidney is dialyzed and put on a diethyl aminoethyl cellulose (DEAE) column in 0.01 M tris buffer.

Can this be interpreted in any other way but that we had been using rhesus monkey kidney cells to make the vaccines?

Other papers mentioning monkey kidney during that era are listed in table 2 (Koprowski 1957, 1961; Plotkin *et al.* 1959, 1961a, 1966; Anonymous 1960; Norton *et al.* 1962; Hayflick *et al.* 1962).

Thus, there is no evidence for the assertion that chimpanzee cells were imported to the Wistar Institute, and no evidence that vaccine made in Philadelphia was prepared in any other cells than those derived from macaque monkey kidneys.

(a) Belgium

A second place where Mr Hooper says chimpanzee cells were used to make OPV was in Belgium. Early in the development of the vaccine, Pieter De Somer, a Belgian virologist at the University of Leuven who in 1953 founded an institute for virology called the Rega Institute, contacted Koprowski. In 1957, with others, he founded a commercial vaccine laboratory as part of a pharmaceutical company called Recherches et Industries Thérapeutiques (RIT), the precursor of SmithKline.

It is extremely unlikely that the Rega Institute would have undertaken vaccine production, in view of the small size of the unit and its dedication to research. Such would have been feasible from 1957 on only at RIT, as a commercial laboratory.

Were chimpanzee cells used to make the vaccine? The testimonies of six people are relevant: Abel Prinzie, Julian Peetermans, Josette Costermans, Monique Lamy, Paul Kolosi and Constant Huygelen, whose functions are listed in table 3. Prinzie (1999) states:

... we *never* (and I absolutely underline never) used chimpanzee tissues or cells, we only used kidney tissue cultures from *Macacus Rhesus*, *Macacus Cynomolgus* and later, *Cercopithecus* (AGM) [i.e. African green monkey].

As far as 'CHAT' strain production is concerned, we may have produced a small pool of virus at the Rega around 1958, just as we reproduced many other poliovirus strains for laboratory purposes. I emphatically deny Hooper's annotation on p. 789 (*The river*) that I said it was 'intended for the Ruzizi valley

Table 3. Statements by Belgians regarding presence of chimpanzee cells at Rega or RIT and their use for production of polio vaccines

name	function	comments
A. Prinzie	Chief Scientist, Rega Institute and later at RIT ^a	never saw/heard of chimpanzee cells
J. Costermans ^b	Chief Technician, Rega Institute	never saw/heard of chimpanzee cells
M. Lamy	scientist, Rega Institute and later at RIT	never saw/heard of chimpanzee cells
J. Peetermans	scientist, Rega Institute and later at RIT	never saw/heard of chimpanzee cells
C. Huygelen	Head of Vaccines, RIT	never saw/heard of chimpanzee cells
P. Kolosi	scientist, Rega Institute	never saw/heard of chimpanzee cells

^a Recherches et Industries Thérapeutiques.

^b Now deceased, quoted by Hooper (1999).

Table 4. *Lots of CHAT vaccine certainly or possibly used in the Belgian Congo*

lot no.	where manufactured	when manufactured	where used
8 or 9	Wistar	1957	New Jersey, north-east Congo
10A-11	Wistar	early 1958	New Jersey, Ruzizi Valley, Sweden, Switzerland
13	Wistar	late 1958	New Jersey, Léopoldville, Poland
4B-5	Wyeth	early 1959	Congo?
DS101	RIT	late 1959	Rwanda-Urundi

vaccination? I resent such a quotation where a mere *hint made by the interviewer* during a conversation later in the book is presented as a solid fact attributed to the interviewee.

Costermans (2000) states:

I was technician at the Rega Institute (Leuven) from 1956 to 1974. During that time I was in charge of tissue cultures and serological testing in the laboratory. I can state categorically that during my stay at the Rega Institute, there never was a chimpanzee in the animal house and we never prepared tissue cultures from chimpanzee organs or tissue.

The statements by Belgian scientists are summarized in table 3.

In early 1959 I tested CHAT vaccine produced in Belgium for the first time, and administered it to babies at Clinton Farms, New Jersey, in April 1959. A document in my files from 1959 mentions the use of CHAT lot 101 from RIT to complete the vaccination of Rwanda-Urundi (Plotkin 1959*a*). Belgian vaccine could only have been used in late 1959 or 1960, which is too late to have been involved in the implantation of HIV. In any case, the essential point is that *even if Belgian vaccine was used in the Congo, it was not made in chimpanzee cells.*

(b) *Stanleyville*

Now we come to the Congo itself. Mr Hooper asserts that CHAT vaccine was produced at the Provincial Laboratory of Stanleyville early in February–March 1958, to allow for the completion of vaccination in Burundi by Dr Ninane. The argument is that CHAT vaccine was in short supply, chimpanzee kidneys were available locally and that Dr Osterrieth whipped up a batch in his virology laboratory at Stanleyville.

Vaccine was indeed in short supply in March 1958, as confirmed by Koprowski in a letter dated 4 March 1958 to George Jervis, who was then in the Congo. But in a postscript to the same letter, writing in response to a telegram from Ninane, Koprowski promises to send more vaccine by the end of March 1958:

P.S. Since I have written this letter, a telegram from Ninane arrived requesting 10,000 capsules of Type 1 and Type 3 and as much liquid vaccine as possible. I am sending him 5000 capsules of each and small amounts of liquid vaccine. I have advised him to request from you more of liquid Type 1 which will be sent to Usumbura end of March.

He makes no reference to local production in the Congo.

Referring to the possibility that CHAT vaccine was produced in Stanleyville, Mr Hooper quotes Dr Gaston Ninane to the effect that he tried but failed to cultivate chimpanzee cells at the Stanleyville laboratory. Dr

Ninane himself vehemently denied this allegation (Ninane 2000):

I never tried to make cell cultures in Stanleyville. The only time I made such attempts was at the University of Liège Consequently, I categorically deny having tried to make tissue cultures from chimpanzees.

The only other person who could have prepared cell culture is Dr Paul Osterrieth, the director of the virology laboratory. His written statement reads as follows (Osterrieth 2000).

I was absent from Stanleyville between October 1957 and January 1958 at which time I attended a course on cell culture and serology at CDC and Wistar. While I was at Wistar I never saw or heard of the use of chimpanzee tissue or cell culture. At my return from the U.S.A., I attempted to set up a cell culture . . . laboratory in Stanleyville. It was difficult to do so because of the lack of the adequate equipment and material. As I recall several months passed, before I was able to succeed in the cultivation of HeLa cells and of kidney cell cultures from baboons. Aside from the limited success with baboon kidney cell culture I also tried to start cell cultures from the kidney of other species of small monkeys. Trypsin was uniformly used to disperse the cells from tissue. . . . *However, at no time did I ever attempt to make cell culture from chimpanzee tissues. In addition, I wish to state categorically that no poliovaccine was ever produced or could have been produced in Stanleyville, since the facilities were totally inadequate for a production or control of poliovaccine.*

In addition to these negative testimonials, there is documentary evidence from the annual reports of the Stanleyville laboratory. The annual reports for 1956 and 1957 say nothing about tissue culture. The crucial 1958 report (Anonymous 1958) says the following: ‘Tissue culture: was done exclusively on cynocephalus [baboon] kidney. 200 tubes and 10 bottles were made. Of the tubes, 36 served for 9 negative analyses. The rest of the tubes and the bottles served to prepare adenovirus antigen for complement fixation.’

I remind you that this is the year when Mr Hooper says CHAT vaccine was prepared at the Stanleyville laboratory in chimpanzee cells. The mere preparation of cell cultures was sufficiently daunting to be mentioned proudly, and yet we are asked to believe that the local production of a polio vaccine for human use would have gone unmentioned.

We also found Paulette Dherte, the pharmacist who served as Paul Osterrieth’s assistant. When asked if polio vaccine was ever produced in Stanleyville, she laughed uproariously and said that was completely impossible.

(c) *Which CHAT lots were used in the Congo?* (Table 4)

The only lots that we can say with certainty were used in the Belgian Congo were pool 8 or 9 in Stanleyville and

some other towns in north-eastern Congo during 1957, pool 10A-11 in the campaign conducted in the Ruzizi Valley (Courtois *et al.* 1958), in children in Sweden (Bottiger *et al.* 1966; Gard *et al.* 1959), in children in Switzerland (Buser & Schar 1961), in infants at Clinton Farms (Plotkin *et al.* 1959*b*) and probably in the Moorestown family trial conducted in Moorestown, New Jersey (Plotkin *et al.* 1960*a*). Pool 13 was used in Léopoldville (Lebrun *et al.* 1960), in children in Poland (Przesmycki *et al.* 1959, 1960) and in infants at Clinton Farms (Plotkin *et al.* 1959). There is no evidence that any of the vaccinations led to HIV infection. It is of interest to note that in one of the Léopoldville papers, it says that pool 13 was 'exactly the same lot as used in Poland' (Plotkin *et al.* 1960*b*).

RIT lot 101 was used in Rwanda-Urundi late in the vaccination campaign.

3. PCR STUDIES

PCR was performed on pool 10A-11 by Dr Jan Albert at the Karolinska Institute in Stockholm, for the detection of HIV/SIV. The result was negative (A. J. Wigzell, personal communication September 12 2000). Unfortunately, no specimen remained for testing of the cell substrate. However, more recently the Wistar Institute organized blind tests in three laboratories of seven other pools of CHAT, including pool 13, which was used in the Congo. All were negative for HIV/SIV, and all lots gave PCR evidence of macaque monkey cellular DNA, but not of chimpanzee cellular DNA (Blancou *et al.* 2001). Thus, the PCR data were inconsistent with the OPV-HIV hypothesis.

4. THE CHIMPANZEE CAMP AT LINDI

The centrepiece of Mr Hooper's detective story is that Koprowski and the Belgian scientist Ghislain Courtois established a camp for chimpanzees at a place called Lindi, near Stanleyville. The purpose of the camp was not at all mysterious. It is stated clearly in a paper by Courtois (1966) and in the 1958 (Anonymous 1958) and 1959 (Anonymous 1959*a*) annual reports of the Stanleyville laboratories, which speak of vaccinating by the oral route a sufficient number of chimps, checking the immune changes thus provoked, and finally infecting them by the oral route with a paralytogenic strain of polio to verify the protective power conferred; checking by intraspinal injection the neurovirulence of the strains used, as well as the possible changes that could have occurred in their pathogenicity after passage through the digestive tract of vaccinated infants; 'trials with the virus of Infectious Hepatitis', with measles and canine distemper virus inoculations in 32 animals, plus isolated experiments on allergic encephalitis, arteriosclerosis and diabetes. Studies of cancer induction in chimps are also discussed for the future (Anonymous 1958, 1959*a*).

With respect to the hepatitis experiments mentioned above, we have Dr Fritz Deinhardt's notebook (Deinhardt 1959). From his notebook we learn that 54 chimpanzees were used in the hepatitis experiments. Their approximate ages, as recorded in the book for 52 of them, are given in table 5, from which we see that with two excep-

Table 5. *Ages of chimpanzees used in hepatitis B experiments at Camp Lindi^a*

age	number of chimpanzees used
<1 year	5
1-2 years	20 ^{b,c}
3-4 years	17
5-6 years	8
7-10 years	2 ^{c,d}
total	52

^a In two cases, neither age nor weight are stated.

^b Ages of two animals estimated from weight.

^c One animal obtained from a zoo.

^d Age of one animal estimated from weight.

tions all animals were less than seven years old and not likely to have been infected with a SIV. One of the two older chimps was acquired from a zoo, but we do not know at what age it came to the zoo, so that only one out of 52 animals was likely to have had sexual experience. That animal was between seven and ten years old, based on his weight of 26 kg. The reason that the chimps were young (aside from the fact that they are easier to catch) is obvious to anyone with experience of them, but is stated by Courtois in another article (Courtois & Mortelmans 1969): 'Apes weighing more than 20 to 25 kg must be considered as unmanageable and very dangerous'.

The Deinhardt notebook also contributes other important pieces of information. The hepatitis experiments began in January 1958 and ended in May 1959. During that 17-month period, 187 liver biopsies were done under anaesthesia. The anaesthetic used was called Nesdonal, which is the brand name of thiopentone sodium, a barbiturate much used for anaesthesia at the time. Undoubtedly, these numerous episodes of anaesthesia for liver biopsy account for the description of anaesthesia allegedly given to Mr Hooper by an African attendant at Camp Lindi.

As far as the issue of kidney removal is concerned, we know that was practised six times for Deinhardt's experiments. However, Mr Hooper claims that additional kidneys were sent to the Wistar Institute and to Belgium for polio vaccine manufacture. His evidence for this is remarks allegedly made to him by two veterinarians who were in Stanleyville, Dr Bugyaki and Dr Mortelmans. However, in a written statement Dr Bugyaki says (Bugyaki 2000):

In the course of my stay in Africa (1949-1959), I heard about the occasional dispatch of chimpanzees from Leopoldville to Belgium, and that already from 1949. Although I don't know towards what destination and for what use, it was certainly not for laboratory use. I have no knowledge of dispatch of chimpanzees to the University of Louvain, nor of the dispatch of chimpanzee kidneys from Lindi camp to Belgium or to other countries.

Dr Mortelmans, who in any case was not present in Stanleyville after 1956, denies any first hand knowledge of chimpanzee organs sent to Philadelphia or Belgium. As a primatologist, he only evoked the possibility of using primate tissues to grow polioviruses. He states (Mortelmans 2000):

On p. 573 [of *The river* (Hooper 1999)] I am alleged to have said that chimp cell culture could have been used for manufacture of polio vaccine, in fact I have no personal knowledge of such ever having been done and this was stated as a hypothetical possibility. Indeed there are very good reasons not to use the chimp for such purpose. Chimpanzees are difficult to catch, difficult to keep and expensive to maintain. Moreover around Stanleyville, baboons, cercopithecus monkeys and colobus monkeys were plentiful and easily available as a preferable source for tissue culture. Similarly on p. 572, it is alleged that I supported the hypothesis that chimp kidneys could have been sent to Philadelphia or Belgium, in fact it only said that such might well have been possible but I have no personal knowledge that it has ever been done.

And what about the people who would have done the autopsies and prepared the kidneys for dispatch elsewhere? Dr Ninane states (Ninane 2000): 'I firmly and categorically declare that I never sent chimpanzee kidneys nor any other organs of these animals towards other countries. I only sent microscopic slides for verification by other laboratories.' Dr Osterrieth acknowledges that he may have helped Fritz Deinhardt send minced kidneys to Philadelphia Children's Hospital, but adds, 'I also want to state very clearly that I never sent chimpanzee kidneys to the Wistar Institute, Philadelphia' (Osterrieth 2000).

5. EPIDEMIOLOGY OF CHAT VACCINATION AND AIDS

The second major assertion in *The river* is that there is an amazing coincidence between sites of CHAT vaccination and early cases of AIDS. Two circumstances are particularly cited by Mr Hooper to show a relationship between CHAT and AIDS. One is a Belgian cartographer and his wife who are said to have been infected in Kikwit, and the other is vaccination in a place called Lubudi, to explain the cases in Katanga.

Kikwit was a town of about 15 000 inhabitants where I went in May 1959 to start a study of immunogenicity. By that time we knew from the Ruzizi trials that African adults were almost all immune to polio, and therefore vaccination was restricted to children under the age of five years. We vaccinated with CHAT and also took blood specimens for pre-vaccination titres. Unfortunately, after bleeding 160 children, the rumour began to circulate that the blood was being taken for the purposes of witchcraft, and the vaccination centre was soon encircled by angry people. The next day we were able to vaccinate only 15 children (Plotkin 1959*b*). We were forced to terminate the study and indeed had to be evacuated from the centre by soldiers.

You can imagine how marked I was by that experience, and you can therefore imagine how surprised I was to read in Hooper's book (Hooper 1999, p. 749) that between one-third and one-half of the population had been vaccinated in May and that vaccinators had returned to Kikwit in November to vaccinate 600 more people. According to Mr Hooper, the Belgian cartographer was included in one of these vaccinations.

The sources given for these statements are Dr André Lebrun and Dr Michel Vandeputte plus one of my own papers. Contact with the two Belgian physicians resulted in denials from both. Dr Vandeputte writes (Vandeputte 2000):

On the first day, we vaccinated the children of the military camp of KIKWIT. Blood samples were taken from most of these children for antibody testing. The second day, the vaccination was pursued amongst the children of the local community but had to be stopped very quickly because of local unrest and protest from the people (i.g. blood sampling at the femoral vein was thought to be cause for later sterility). As far as I can remember, we vaccinated during this period no more than a few hundred children.

None of us recollects the vaccination of European adults in May, but what about November? I reread my paper (Plotkin *et al.* 1961*b*) and saw that Mr Hooper was basing his idea on the following sentences:

Of particular interest is virus 525, isolated from a 32-year old European woman who developed poliomyelitis one month after coming to a village in the Congo. In this village and in neighbouring villages during the latter part of 1959 there had been several cases of type 1 poliomyelitis. Consequently, on 30 November 1959, CHAT was administered to 374 Europeans of all ages and 253 African children less than 5 years old.

In my files there is a facsimile transmission, which refers to vaccination in a place called Moanda of 374 Europeans and 253 Congolese, in relation to the case of Madame de Jonghe, a Dutch woman who developed polio on 10 January 1960, which corresponds exactly with the episode referred to in my paper. Moanda is on the Atlantic coast, some 730 km (450 miles) from Kikwit, which may be too far even by Mr Hooper's generous standards of geographical proximity. Thus it is unlikely that the Belgian cartographer was vaccinated.

A second circumstance emphasized by Mr Hooper is an alleged vaccination site at Lubudi, to explain cases that occurred 100 or 175 miles away. The evidence for vaccination is based on a newspaper article (Anonymous 1959*b*). Lubudi is in Katanga Province where, so far as I know, no vaccination was ever done because the health authorities were opposed to the concept of live poliovirus vaccination. Two of those authorities are still alive: Dr Jean Delville and Dr Stephane Pattyn, formerly provincial medical director and laboratory director, respectively. Both deny that vaccination was done in Katanga (Delville 2000; Pattyn 1999).

I returned to the newspaper article that spoke of the planned vaccination and saw that it in fact referred to 'Kabare-Lubudi'. Kabare is just north of the Ruzizi Valley, and to the west by road is Lubutu, whereas Lubudi is almost 500 miles to the south. I think it is more likely that the reporter made a mistake in spelling than that we referred to two places so distant from one another.

Thus, the two AIDS cases that would be most useful to bolster Mr Hooper's case are unrelated to sites of CHAT vaccination.

What about the general idea that vaccination sites and AIDS cases before 1980 are juxtaposed? First, it is important to note that only 10 of 38 cases listed by Mr Hooper were confirmed to be HIV infections. However, let us for the sake of argument accept them all as AIDS cases. Mr Hooper then claims that 'of the 28 patients for whom a specific town is cited, 23 come from the Congo, Rwanda, or Burundi and of these, fully 17 are linked to towns where CHAT was previously fed. The other six are linked to places situated within 175 miles of towns where CHAT

Table 6. Incidence of putative cases of AIDS in the Belgian Congo before 1980 cited by Hooper (1999)

place	estimated population ^a (thousands)	no. of cases	incidence per 100 000
Léopoldville	273	13	4.8
Stanleyville	72	2	2.7
Bukavu	30	1	3.0
Elisabethville	140	1	0.7
all towns above	515	17	3.4
all urban	1261	17	1.3
rural and mixed	11 510	5	0.4

^a Data from Anonymous (1961).

is known or believed to have been fed.' (Hooper 1999, p. 743) Why was 175 miles chosen? Why not 50 or 500? I think the statisticians call that type of correlation 'data fishing'.

But just how significant is that observation? In fact, 13 of the 17 cases where vaccination and disease match come from the metropolis of Léopoldville and two from the city of Stanleyville. Thus 15 of the 17 matches between vaccination and AIDS are scarcely surprising, occurring in two major urban areas.

Moreover, as shown in table 6, the distribution of AIDS cases (if they were AIDS cases) shows a strong urban/rural difference. For the four towns where there were cases, the incidence was 3.4 per 100 000; for all urban areas it was 1.3 per 100 000; while for rural areas the incidence was down to 0.4 per 100 000.

Finally, if we now look at the map (figure 2) from which the Kikwit cases and the Lubudi vaccination sites have been removed, we see that in the Bas Congo and in Province Oriental there is CHAT vaccination and no AIDS, while in Katanga there is AIDS but no CHAT vaccination.

(a) Vaccination in Burundi

Mr Hooper makes a particular case for CHAT having been the source of HIV infection during a vaccination campaign along the eastern shore of Lake Tanganyika, from Usumbura to Nyanza Lake (Hooper 1999, p. 788): 'It is rather the CHAT 10A-11 vaccine used in 1958 for the second (Lake Tanganyika) leg of the Ruzizi Valley trial, vaccine that was fed in places like Usumbura and Rumonge, which coincides most precisely with the early appearance of HIV some years later'.

The basis for this so-called early appearance of HIV is seroprevalence data obtained in 1980–81 by Morvan *et al.* (1989). They found the prevalence was higher in the city

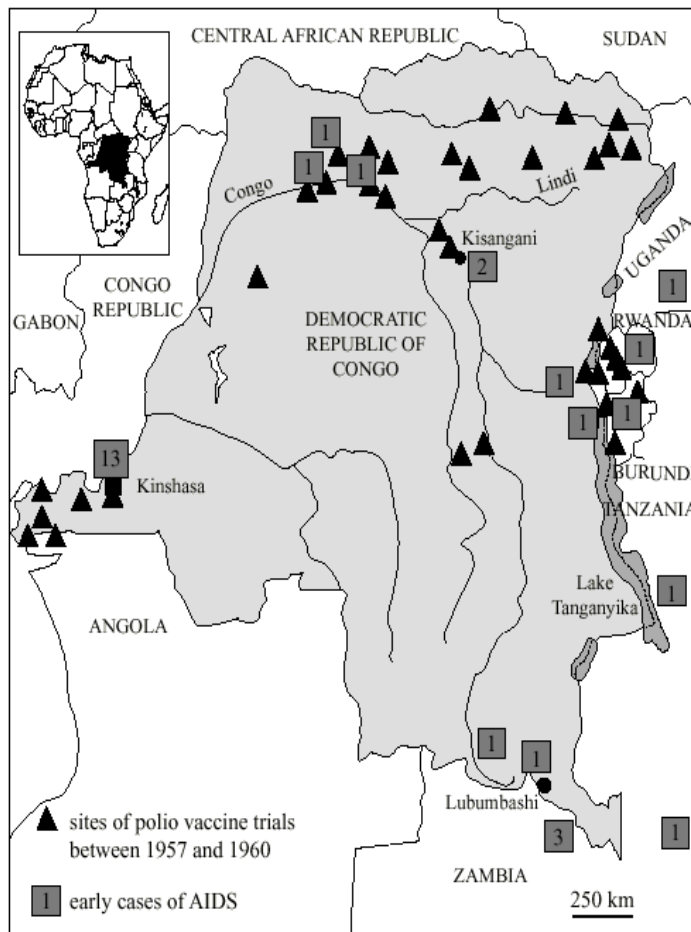

Figure 2. Montage of two maps of the former Belgian Congo and neighbouring countries from *The river*, showing locations of putative AIDS cases before 1980 and sites of CHAT vaccination. Modified, with permission, from 'Jeune Afrique' 25–31 January 2000.

Table 7. *HIV-1 serology results on sera obtained by A. Motulsky in 1959^a*

place	no. positive/ no. tested	age	tribe
Léopoldville	1/99 (85) ^b	adult	Bantu
Stanleyville	0/98 (84)	adult	Bantu
Bukavu	0/116 (99)	10–20 years	Shi
Astrida	0/90 (77)	10–20 years	Tutsi
Nyanza	0/99 (85)	10–20 years	Hutu

^a See Motulsky *et al.* (1966); Giblett *et al.* (1966).

^b Figures in parentheses are numbers calculated on the apparent 14.5% loss of specimens lost between collection and testing for HIV-1 antibodies (Nahmias *et al.* 1986).

of Usumbura (8.1%) than in the rural area (2.8%), which is consistent with an epidemic propagated by sexual transmission, but the prevalence in a village named Rumonge was 11.9%. Although the figure was based on only eight positive sera among 67 tested, Mr Hooper nevertheless makes a great point about this, but fails to quote the explanation given in the paper by the authors themselves: 'At Rumonge, where there existed a high frequency of seropositives (11.94%), there was a Burundu–Zairois population comparable to a semi-urban environment with free sexual morals'. Dr Bernard Carteron, one of the authors, also told me that there were many Zairean truck drivers in Rumonge.

Moreover, while everybody knows of the seropositive adult from Léopoldville in 1959 (Nahmias *et al.* 1986), fewer have noted that Motulsky also obtained sera from children in the Ruzizi Valley and in Burundi who probably had been vaccinated with CHAT in 1958 (Motulsky *et al.* 1966; Giblett *et al.* 1966). All were seronegative (table 7).

(b) *Clinton Farms and the American AIDS epidemic*

Mr Hooper has also proposed an explanation for the introduction of HIV into the United States: namely, that during our early trials of immunization in a women's prison in New Jersey, called Clinton Farms, CHAT vaccine contaminated with SIV was administered to infants. He calls attention to a case of paediatric AIDS reported by Dr James Oleske, a paediatrician from Newark (Oleske *et al.* 1983). The child in question was born in 1974 to a 16-year-old drug-addicted mother. The contention is that the mother had been an infant at Clinton Farms and was one of the CHAT vaccinees.

However, Dr Oleske has ruled out this possibility. Dr Oleske writes (Oleske 2000):

I have reviewed a list of names of children born during 1956 to 1958 to mothers incarcerated at what is now known as the Clinton Detention Center, New Jersey. The list was supplied to me under confidentiality by the New Jersey State Department of Health. Based on my patient records and a review of this list, I can not identify any name on the list of babies that corresponds with the mother of an HIV-infected infant seen by me in the late 1970s and reported in the *Journal of the American Medical Association*.

Thus, this hypothesis also has no facts to support it.

6. REFLECTIONS

After all is said, we are left with the same facts that were widely known when Mr Hooper started writing his book: namely, that AIDS became apparent as a disease in the same country where CHAT OPV vaccination was done, and that chimpanzees were available to those who made the vaccine.

There is a special irony in the accusation that we were oblivious to the threat of extraneous agents in primary cell culture. To avoid that threat Dr Koprowski and I were the first to apply the human diploid cell strains developed by Hayflick & Moorhead (1961) to the creation of vaccines, first for polio, and then later in Hilary's case for rabies (Wiktor & Koprowski 1965) and, in my case, for rubella (Plotkin *et al.* 1965) and other vaccines.

The river has been praised for its precise detail and wealth of footnotes, but one can be *precise* without being *accurate*.

The issue in the case under consideration is not whether contamination of vaccine with HIV *might* have happened, but whether in fact it *did* happen. Of course, it is well known that science does not prove negatives. All things are possible, including goblins and ghosts. A thousand hypotheses are daily born, but few live to evening. To accept a hypothesis science demands not only association in time but also the absence of conflicting data. By this test, the OPV–AIDS hypothesis fails.

In summary, not a shred of evidence supports the idea that chimpanzee cells were actually used to make polio vaccine, and the supposed geographical correlation between vaccination and AIDS is an illusion. Moreover, the ancillary virologic and epidemiological data are against the OPV–AIDS hypothesis, as discussed at this symposium by Hahn, Korber, Sharp, Beale, Vandamme, De Cock and others.

The river does not withstand critical analysis. The energy deviated by this controversy should now return to research that seeks to end the AIDS epidemic, notably through vaccine development.

REFERENCES

- Anonymous 1958 Annual Report. Stanleyville: Congo Belge Laboratoire Medical Provincial.
- Anonymous 1959a Annual Report. Stanleyville: Congo Belge Laboratoire Medical Provincial.
- Anonymous 1959b La lutte contre la polio au Congo: une nouvelle etape. *Courier d'Afrique* (May 4 1959), p. 4.
- Anonymous 1960 *Protocols: production and control, attenuated poliomyelitis type I–CHAT–Lot 23*. Philadelphia, PA: Wistar Institute.
- Anonymous 1961 Tableau général de la démographie Congolaise. République du Congo Gouvernement Central Ministère du plan et de la coordination économique. Service des statistiques.
- Blancou, P., Vartanian, J. P., Christopherson, C., Chenciner, N., Basilico, C., Kwok, S. & Wain-Hobson, S. 2001 Polio vaccine samples not linked to AIDS. *Nature* **410**, 1045–1046.
- Bottiger, M., Bottiger, E. & Zetterberg, B. 1966 Vaccination with attenuated type 1 poliovirus, the CHAT strain. III. Antibody response and spread of virus in schoolchildren. *Acta Paediatrica Scan.* **55**, 422–431.
- Bugyaki, L. 2000 Letter to Abel Prinzie, 4 February 2000.
- Buser, F. & Schar, M. 1961 Poliomyelitis vaccination with live poliovirus. *Am. J. Dis. Child* **101**, 60–66.

- Cohen, B. 1999 Notarized statement, 15 November 1999.
- Costermans, J. 2000 Signed statement, 8 February 2000.
- Courtois, G. 1966 Sur la réalisation d'une singerie de chimpanzées au Congo. Extrait. *Symposium International sur l'avenir des animaux de laboratoire, Lyon, 18 September 1966*, pp. 235–244. Lyon: Institut Mérieux.
- Courtois, G. & Mortelmans, J. 1969 Apes. *Primates Med.* **2**, 75–86.
- Courtois, G., Flack, A., Jervis, G., Koprowski, H. & Ninane, G. 1958 Preliminary report on mass vaccination of man with live attenuated poliomyelitis virus in the Belgian Congo and Ruanda-Urundi. *Brit. J. Med.* **2**, 187–190.
- Deinhardt, F. 1959 Notebook. (Unpublished.)
- Delville, J. P. 2000 Translated, signed statement, 6 January 2000.
- Gard, S., Bottiger, M. & Lagercrantz, R. 1959 *Vaccination with attenuated poliovirus type 1, the CHAT strain*. Pan American Sanitary Bureau, Scientific Publication no. 44, pp. 350–354. Washington, DC: Pan American Sanitary Bureau.
- Giblett, E. R., Motulsky, A. & Fraser, G. R. 1966 Population genetic studies in the Congo. IV. Haptoglobin and transferrin serum groups in the Congo and in other African populations. *Am. J. Hum. Genet.* **18**, 553–558.
- Hayflick, L. & Moorhead, P. S. 1961 The serial cultivation of human diploid cell strains. *Fed. Proc.* **20**, 150.
- Hayflick, L., Plotkin, S. A., Norton, T. W. & Koprowski, H. 1962 Preparation of poliovirus vaccines in a human fetal diploid cell strain. *Am. J. Hyg.* **75**, 240–253.
- Hooper, E. 1999 *The river: a journey to the source of HIV and AIDS*. New York: Little, Brown & Co.
- Koprowski, H. 1957 Discussion. *Spec. Publ. NY Acad. Sci.* **5**, 128–133.
- Koprowski, H. 1958 Letter to George Jervis, 4 March 1958.
- Koprowski, H. 1961 Live poliomyelitis virus vaccines. *JAMA* **178**, 1151–1155.
- Lebrun, A., Cerf, J., Gelfand, H. M., Courtois, G., Plotkin, S. A. & Koprowski, H. 1960 Vaccination with the CHAT strain of type 1 attenuated poliomyelitis virus in Léopoldville, Belgian Congo. 1. Description of the city, its history of poliomyelitis, and the plan of the vaccination campaign. *Bull. WHO* **22**, 203–213.
- Motulsky, A., Vandepitte, J. & Fraser, G. R. 1966 Population genetic studies in the Congo. *Am. J. Hum. Genet.* **18**, 514–537.
- Mortelmans, J. 2000 Signed statement, 20 April 2000.
- Morvan, J., Carteron, B., Laroche, R., Bouillet, E., Teyssou, R. & Blanchard de Vaucouleurs, F. 1989 Enquête Séro-Epidémiologique sur les infections à HIV au Burundi entre 1980 et 1981. *Bull. Soc. Path. Exot.* **82**, 130–140.
- Nahmias, A. J. (and 11 others) 1959 Evidence for human infection with an HTLV III/LAV-like virus in Central Africa, 1959. Letter. *The Lancet* 1986 **1**, 1279–1280.
- Ninane, G. 2000 Translated signed statement, 22 February 2000.
- Norton, T., Carp, R. & Plotkin, S. A. 1962 Summary of feeding results with attenuated polioviruses grown in human diploid cell strains. July 5 1962. WHO virus disease document WP16. Geneva: World Health Organization.
- Oleske, J. 2000 Letter, 11 July 2000.
- Oleske, J., Minnefor, A., Cooper Jr, R. J., Thomas, K., de la Cruz, A., Ahdieh, H., Guerrero, I., Joshi, V. & Desposito, F. 1983 Immune deficiency syndrome in children. *JAMA* **249**, 2345–2349.
- Osterrieth, P. M. 2000 Signed statement, 28 February 2000.
- Pattyn, S. R. 1999 Signed statement, 25 November 1999.
- Pigliucci, M. 2000 Why everyone believes in fairy tales. *Skeptical Inquirer* **24**, 50–51.
- Plotkin, S. A. 1959a Protocol for vaccination in Ruanda-Urundi. Plotkin files.
- Plotkin, S. A. 1959b Vaccination records from Kikwit. Plotkin files.
- Plotkin, S. A. 1961 Factors influencing a successful vaccination with live polio virus. *Proceedings of the Sixth International Congress of Microbiol. Standards, Wiesbaden, 1960*, pp. 48–73. Berlin: Hoffmann-Verlag.
- Plotkin, S. A. 2001 CHAT oral polio vaccine was not the source of human immunodeficiency virus type 1 group M for humans. *Clin. Infect. Dis.* **32**, 1068–1084.
- Plotkin, S. A., Jervis, G., Norton, T. & Stokes, J. 1959a Persistence of antibodies after vaccination with living attenuated poliovirus. *JAMA* **170**, 8–12.
- Plotkin, S. A., Koprowski, H. & Stokes, J. 1959b Clinical trials in infants of orally administered attenuated poliomyelitis viruses. *Pediatrics* **23**, 1041–1062.
- Plotkin, S. A., Koprowski, H., Richardson, S. M. & Stokes, J. 1960a Vaccination of families against poliomyelitis by feeding and by contact spread of living attenuated virus including studies of virus properties after human intestinal passage. *Acta Paediatrica Scand.* **49**, 551–571.
- Plotkin, S. A., Lebrun, A. & Koprowski, H. 1960b Vaccination with the CHAT strain of type 1 attenuated poliomyelitis virus in Léopoldville, Belgian Congo. 2. Studies of the safety and efficacy of vaccination. *Bull. WHO* **22**, 215–234.
- Plotkin, S. A., Cohen, B. J. & Koprowski, H. 1961a Intratypic serodifferentiation of polioviruses. *Virology* **15**, 473–485.
- Plotkin, S. A., Lebrun, A., Courtois, G. & Koprowski, H. 1961b Vaccination with the CHAT strain of type I attenuated poliomyelitis virus in Léopoldville, Congo. 3. Safety and efficacy during the first 21 months of study. *Bull. WHO* **24**, 785–792.
- Plotkin, S. A., Cornfeld, D. & Ingalls, T. H. 1965 Studies of immunization with living rubella virus: trials in children with a strain cultured from an aborted fetus. *Am. J. Dis. Child* **110**, 381–389.
- Plotkin, S. A., Katz, M., Brown, R. E. & Pagano, J. S. 1966 Oral poliovirus vaccination in newborn African infants. *Am. J. Dis. Child* **111**, 27–30.
- Prinzic, A. 1999 Signed statement, 9 December 1999.
- Przesmycki, F., Dobrowolska, H., Olakowski, T., Stanczyk, R. & Naruszewicz, D. 1959 Report on field trials with live attenuated poliomyelitis vaccine in Poland. *First Int. Conf. on Live Poliovirus Vaccines, Washington, DC, 22–26 June 1959*. Pan American Sanitary Bureau Publication no. 44, pp. 497–507. Washington, DC: Pan American Sanitary Bureau.
- Przesmycki, F., Dobrowolska, H., Georgiades, J., Olakowski, T., Stanczyk, R. & Naruszewicz, D. 1960 Report on field trials with live attenuated poliomyelitis vaccine of Koprowski in Poland. *Am. J. Hyg.* **71**, 275–284.
- Vandepitte, M. 2000 Signed statement, 2 February 2000.
- Wiktor, T. J. & Koprowski, H. 1965 Successful immunization of primates with rabies vaccine prepared in human diploid cell strain WI-38. *Proc. Soc. Exp. Biol. Med.* **118**, 1069–1073.